



AN IMPROVED MULTI LEVEL IUPQC FOR VOLTAGE REGULATION

Ramesh Gupta Pasumarthi¹ & Durga Prasad Bandaru²

Abstract- This paper presents iUPQC, the curved current supply and the curved voltage supply are given to the PAF and SAF converters in the UPQC. This design offers a circuitous PQ pay for the heap voltage and the supply current. Ancient studies have suggested that iUPQC has specialized points of interest in interconnection with the standard UPQC owing to its lessened shift frequency trademark. This can be accustomed management to the ability flow within the transmission by dominant electrical resistance, voltage magnitude. Distinctive in relevance a normal iUPQC and UPQC are designed with the series converter which is controlled as a curved current supply and also the shunt converter is controlled as a curved source voltage. There by the hierarchal no. of levels in the converters, injected voltages or currents gets nearer to the sinusoidal, during this process we have a tendency to accomplish higher doctorate esteem. The execution of the planned system is mimicked in MATLAB/Simulink surroundings.

Keywords – Voltage regulation, UPQC, Micro Grid, Sinusoidal reference, Harmonic content

1. INTRODUCTION

To reinforce the standard PQ values in the smart grids and micro grids the obtainable technique is the internal control of UPQC. The capability of the UF-PQ, the designed conditioner is get rid of the magnified influences the execution of the fundamental load at power framework. As UPQC have the capacity of refining the PQ at the aim of power appropriation framework. There by the UPQC is needed to be the best equipment among the foremost effective answers for the required limits to provide the voltage gleam/unevenness [2]. The UPQC that have 2 converters that gives dc association, will repay the voltage gleam and unevenness, the harmonious current and harmonious voltage and the forced stream is managed and solidness of the voltage. This UPQC consists of double dynamics, the covenant of dynamic channel (SAF). Here the PAF are controlled as non- curved voltage supply which is answerable of repaying the harmonious current of the hike, the SAF are controlled as a non-curved voltage source which is answerable of remunerating the voltage network. The referral to both SAF and PAF are area unit curved. This paper proposes a system for multi level inverter along (iUPQC) topology which enforces the streams and voltages at higher THD levels into utility framework associated.

2. PROBLEMS IN POWER QUALITY

Power quality has distinctive implications to various customers. (IEEE) public IEEE1100 characterizes power quality as “the design of grounding and the power supply to the sensitive equipment in a very appropriate manner for the equipments” [4]. There is a good scope on PQ problems connected with the grid frameworks taking under desired time, as an example, future varieties, transient time varieties and totally different unsettling influences.

Origin of poor performance in power quality

The Power Quality poor performances are recorded as takes after [5]:

- Arc heaters
- Speed drives
- Power supply switching
- Electronic Fluorescent light weights
- Lightning Strike
- Non-linear load
- Starting the extensive engines

3. DUAL TOPOLOGY OF UNIFIED POWER QUALITY CONDITIONER

The customary structure of UPQC is fabricated out of a PAF and a SAF, which are incontestable as shown in Fig. 1. During the setup of SAF functions as a voltage source thus to repay the framework disturbances, unbalances and aggravations like voltage swells, voltage sag and fluctuation. During this manner SAF is fabricated out of the principal part to repay the voltages and also the harmonics. The PAF behave like the current supply and it countable of repaying all the unevenness and harmonics of the load current, guaranteeing a curved current network.

¹ Department of Electrical and Electronics Engineering, Gitam (Deemed to be University), Visakhapatnam, Andhra Pradesh, India

² Department of Electrical and Electronics Engineering, Gitam (Deemed to be University), Visakhapatnam, Andhra Pradesh, India

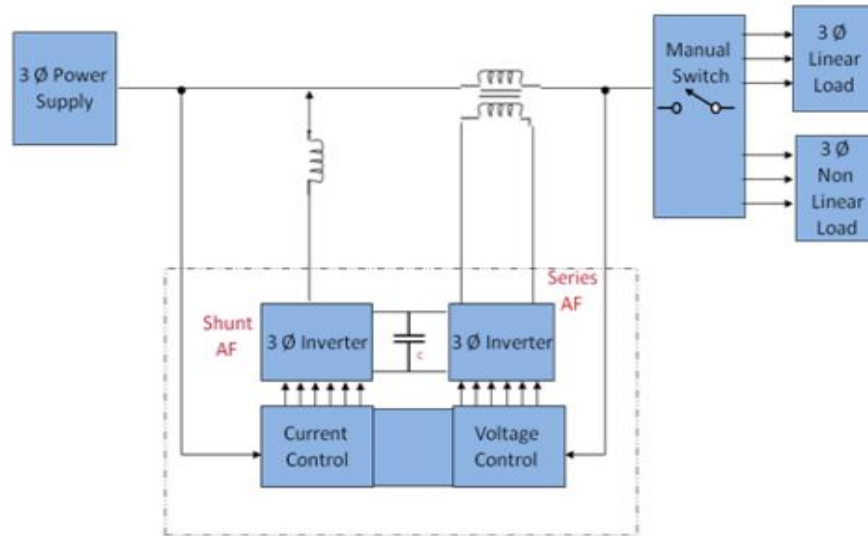

Figure 1. Convectional UPQC

The customary UPQC has the related to disadvantages are complicated extraction of the harmonic grid voltages and thereby the load connected together with complicated fluctuations, current and the voltage references with contents of harmonics obliging a high knowledge measure management and therefore the spillage inductance of the series association electric equipment influencing the compensation of the voltage made by the series channel. For attenuating these downsides, the iUPQC is examined in this paper and this arranges is incontestable within the Fig.2

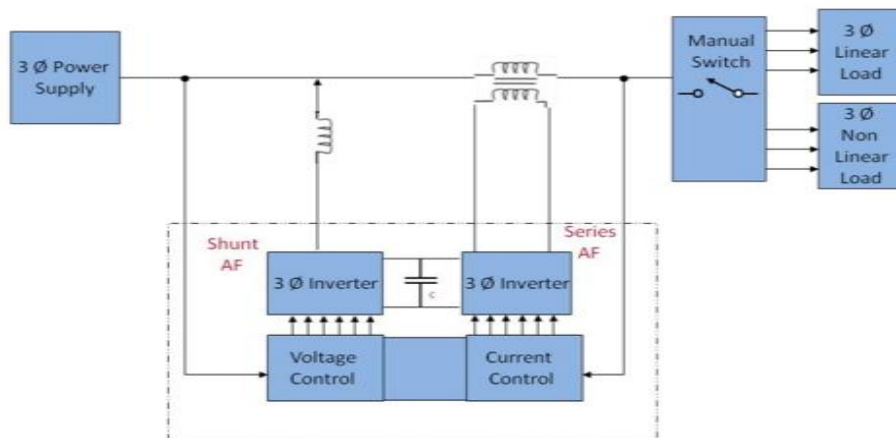

Figure.2. Dual UPQC.

4. PROPOSED CONTROL SCHEME

The projected iUPQC management structure is the SAF associated PAF area unit controlled in an autonomous path, indicated in Fig. 3. Over the projected management conspire, the ability computation and harmonic extraction don't seem to be needed following the harmonic, disturbances, unevenness and displacements are adjusted. The (SAF) Series Active Filter features a current loop keeping in mind the tip goal to ensure the curving network synchronic current with the network voltage. The Parallel Active Filter (PAF) features a loop voltage to know the adjusted voltage burden with harmonic bending low in content. This management loops area unit autonomous from others because they freely act in each dynamic channel. The voltage management at the dc link is made within the SAF, wherever the loop voltage decides the reference amplitude for this loop, within the design technique of the ability concern converter management plans. The curved references to PAF and SAF controllers are created by particularly performed sign processor that guarantees the network voltage about relation utilizing (Phase Locked Loop) PLL.

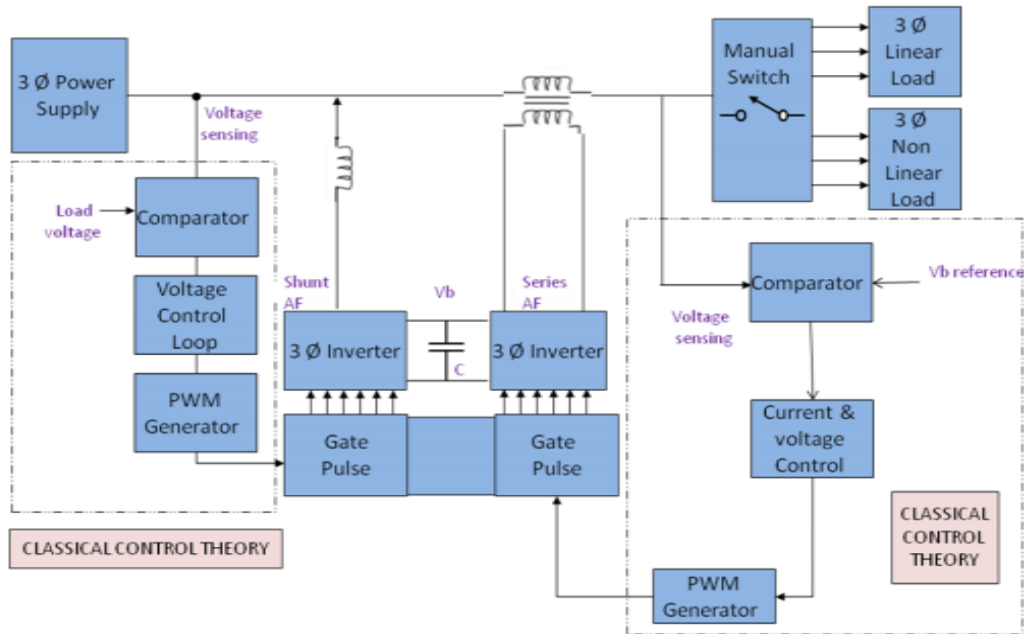

Figure.3 Control of iUPQC

5. SIMULATION RESULTS

We know the importance of PQ, it is mandatory to identify these iUPQC with very better THD in the PS. FACTS appliance can regulate the VAR and VA control as to evolve to voltage-hike control at the same time due to their flexibility and fast control characteristics Multilevel design of converters in which it cause to operate the line flow and maintain bus voltages in crave levels with more good quality of wave-shapes and so this improves the voltage stability margins. This paper proposes a method to control the power quality problems by using the MUTI LEVEL CONVERTER IN THE FACTS DEVICES to be installed. These FACTS DEVICES models are incorporated busing SIMULINK modeling source.

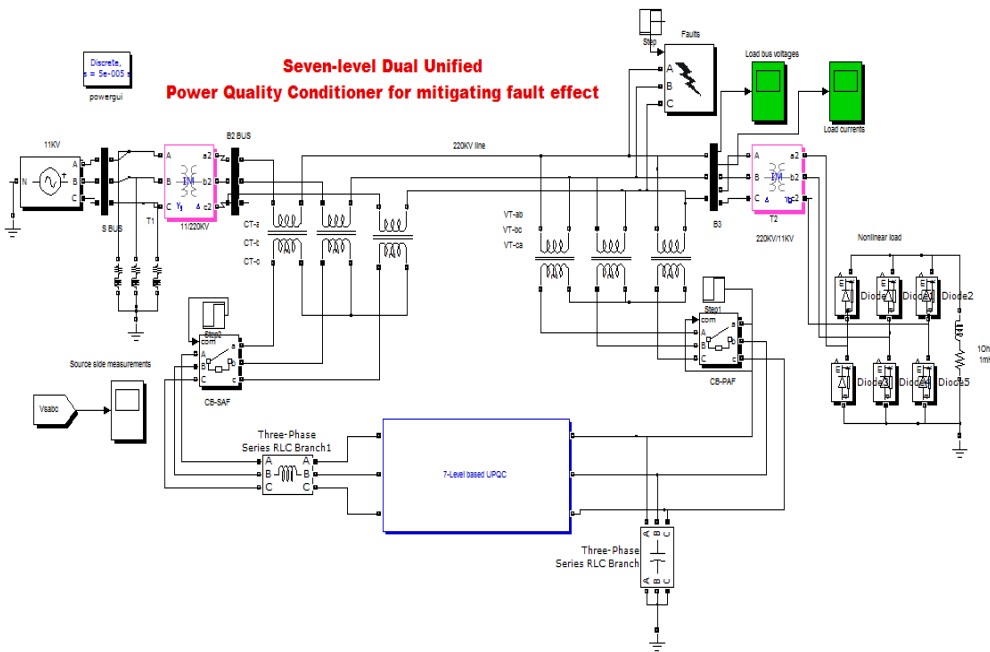

Figure 4: Simulation circuit diagram

The parameters related to the simulation part of the PS area unit given below, supply fact parameters, SAF parameters, PAF parameters, THD factor.

Source side parameters

AC Voltage Supply, $V_s=11KV$,
Supply frequency, $f_s=50Hz$, 3-Ph
Voltage at DC link, $V_{dc}=750V$

Shunt active power filter parameters

AC inductive reactance $L_A=1mH$
DC inductive reactance= $10mH$
DC capacitance= $2200\mu F$
DC resistance $R_L=100\text{ Ohm}$

Series active power filter parameters

Transformer rate =1:3
AC inductive Reactance $L_c=3.5mH$
Switching frequency, $F_s=10\text{ KHz}$
AC filter R_f & $C_f=5\text{ohm}$ & $3\mu F$

5.1 Waveforms

Input 3-Ph supply voltage V_s (Volt) of the system is shown in the figure.5.

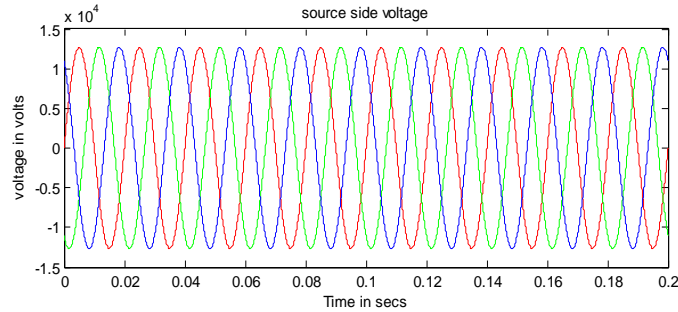

Figure.5. Input 3-Ph Supply Voltage V_s

Load side voltages without iUPQC V_L (volts)of the system is as shown in the figure.6.

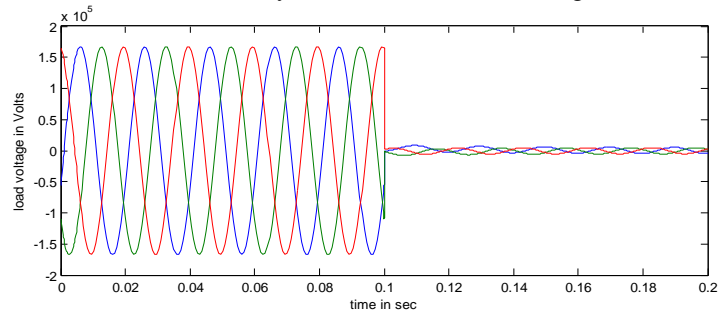

Figure.6. Load side voltage without iUPQC.

Here we are able to see, drop by the load bus voltages as a result of external disturbances. To eliminate this unwanted situation, inject iUPQC in to the system.

Load side voltages-With iUPQC V_L (volts) of the system is as shown in the figure.7.

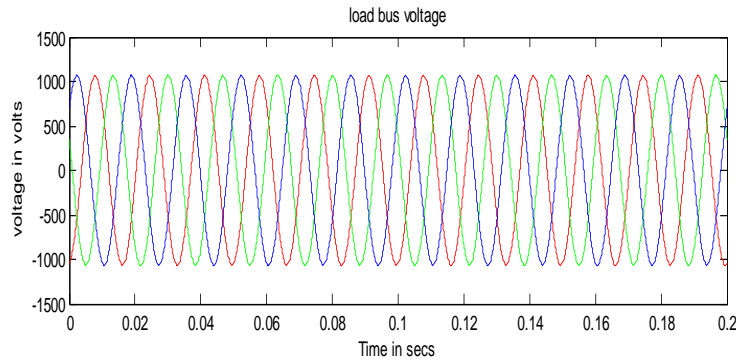

Figure.7. Load side voltage-with iUPQC.

In the presence of iUPQC we can see that voltage dip can be overcome to provide Voltage stability at load bus side. Voltage injected by seven-level iUPQC into the system is as shown in the figure.8.

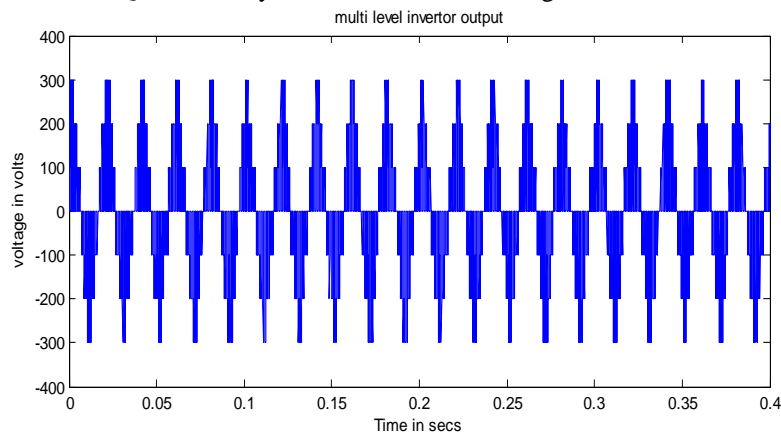

Figure.8. Voltage injected by the seven-level iUPQC.

Voltage stability is done by iUPQC is by injecting some voltage into the system.

Harmonic level

THD- is the live content of harmonics within the voltage injected. THD by deception UPQC=1.407 THD by using gift system=0.734.

Now we will see improvement within the quality of voltages Injected by iUPQC. Enhanced in percentage within the doctor's degree = $(1.407-0.734)/1.407*100=47.3\%$

6. CONCLUSION

The 3-phase non linear devices connected in industries are the root reasons of PQ problems and harmonics insertion into the framework. In ancient methods in order to bypass these PQ problems the devices used are UPQC and STATCOM and now for the better responses an iUPQC is designed for voltage regulation for the load side and grid side by providing the VAR compensation. This power is calculated from synthesized current which is produced by the SAF. This required power is for the load and the power losses. Now in order to reduce the harmonic content in the injected voltage in the framework the designed iUPQC consists of multi levels in the converter.

7. REFERENCES

- [1] Akagi, H. and Fujita, H., "A new power line conditioner for harmonic compensation in power systems," IEEE Trans. Power Del., vol. 10, no. 3, pp. 1570–1575, Jul. 1995.
- [2] Fujita, H. and Akagi, H., "The unified power quality conditioner: The integration of series and shunt-active filters," IEEE Trans. Power Electron., vol. 13, no. 2, pp. 315–322, Mar. 1998.
- [3] C. Sankaran, "Power Quality", CRC Press LLC, 2002
- [4] Alexander Kusko and Marc T. Thompson, "Power Quality in Electrical Systems", McGrawHill, 2007.
- [5] A. Ghosh, and A. Joshi, "Interline unified power quality conditioner," IEEE Trans. on Power Deliv., vol. 22, no. 1, pp. 364–372, Jan 2007.
- [6] S. Das and Y. Kolhatkar, "Experimental investigation of a single-phase upqc with minimum va loading," IEEE Trans. on Power Deliv., vol. 22, no. 1, pp. 373–380, Jan 2007.
- [7] S. Das, and G. Dubey M. Basu, "Investigation on the performance of upqc-q for voltage sag mitigation and power quality improvement at a critical load point," IET Generation Transmission Distribution, vol. 2, no. 3, pp. 414–423, May 2008.
- [8] A. Chandra, and V. Khadkikar "A new control philosophy for a unified power quality conditioner (upqc) to coordinate load-reactive power demand between shunt and series inverters," IEEE Trans. on Power Deliv., vol. 23, no. 4, pp. 2522–2534, Oct 2008.

-
- [9] R. Fernandes and M. Aredes, "A dual topology of unified power quality conditioner: The iupqc," in 13th European Conf. on Power Electron. And Appl., Sept 2009, pp. 1–10.
- [10] M. Brenna and E. Tironi, "A new proposal for power quality and custom power improvement: Open upqc," IEEE Trans. on Power Deliv., vol. 24, no. 4, pp. 2107–2116, Oct 2009.
- [11] M. Simoes and S. Chakraborty "Experimental evaluation of active filtering in a single-phase high-frequency ac microgrid," IEEE Trans. on Energy Conversion, vol. 24, no. 3, pp. 673–682, Sept 2009.
- [12] A. Chandra, and V. Khadkikar "A novel structure for three-phase fourwire distribution system utilizing unified power quality conditioner (upqc)," IEEE Trans. on Ind. Appl., vol. 45, no. 5, pp. 1897–1902, Sept 2009.
- [13] H. Akagi, E. H. Watanabe and M. Aredes, Instantaneous Power Theory and Applications to Power Conditioning. Wiley-IEEE Press. April 2007
- [14] B.Durga Prasad,A.Sriteja,M.Ravindrababu and K.Manohar " A novel technique for protection of TCSC compensated transmission line" IFRSA's internation journal of computing, vol.1,issue 3,july2011.
- [15] M.Praveen,B.Durga Prasad and S.Ramana kumar joga "A Power quality improvement of mitigating neutral current for VSC based DSTATCOM using TIES" internation journal of engineering research and applications,vol 2,issue 1,jan-feb 2012,pp.579-585.